

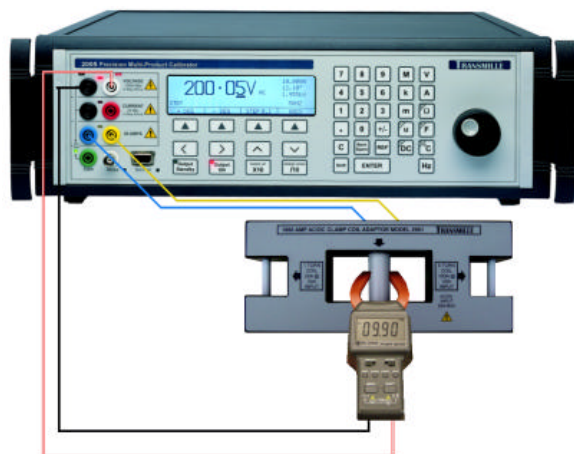

# AC / DC Power Calibration Option For the 2000 Series Calibrators

## Affordable AC / DC Power Calibration PWR

- AC and DC modes
- Internal retro-fittable option\*
- Up to 1MW (using 50 Turn Clamp Coil)
- 40Hz to 400Hz frequency range
- 0° to ± 359.9° adjustable phase relationship



A complete solution for the accurate calibration of power (Watts) and VA ranges on power meters, power analysers & clamp meters, the power option for the 2000 series calibrators allows both voltage current output to be generated simultaneously with an adjustable phase angle relationship.

Any voltages up to 1000 Volts can be set using the normal output ranges and specification of the calibrator. Currents up to 20Amps with 2mA resolution are available from the 20Amp output of the calibrator without the need for an external amplifier.

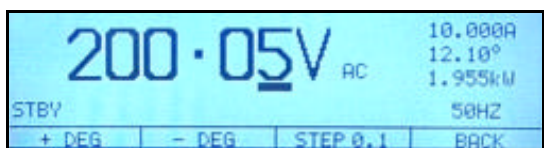

The power function is extremely simply to use, simply select 'Power' from the soft key menu under the display, connect the Power meter to both the voltage and 20Amp output terminals, and enter the voltage, current, frequency and phase angle required.

The phase angle can easily be changed leaving the voltage/current set using the soft menu keys.

Simply select the DC button when in power mode for DC power operation.

### AC Power :: Dynamic Digital Phase Control

The 2000 series calibrator dynamically controls the phase angle between the current and voltage waveforms eliminating errors caused by capacitive or inductive loading experienced when using clamp coils.

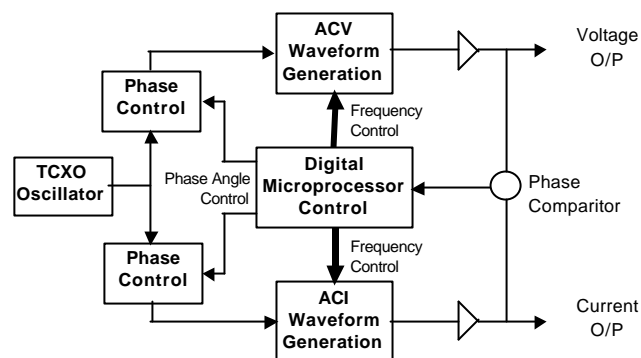

### Extended the power range Using the 1 / 5 / 50 Clamp Coil Adapter

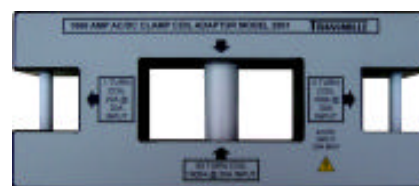

Combined with the optional clamp coil adapter the power calibration option allows a current of 1000Amps to be simulated, and power to 1Megawatt (1000Amps x 1000Volts).

**The equations below explain the relationship between Watts, Current, Voltage & Phase Angle.**

**Active Power :** Watts = Voltage x Current x Cosine 'Phase angle'

**Apparent Power :** VA = Volts x Current

**Power Factor :** PF = Active Power / Apparent Power

**Phase Angle :** F = Angle of AC Current shift from Voltage

### Automating Power Meter Calibration Using ProCal Software

Power calibration can be fully automated by using ProCal to control the 2000 Series calibrator using a PC. The 2000 Series calibrator is controlled via the RS232, removing the need for expensive interface cards. Alternatively, control can also be achieved via the GPIB interface option if required.



## Power Calibration Option - Operation

The power option for the 2000 Series calibrators calibrator can simulate power by simultaneously outputting voltage and current with an adjustable phase relationship.

### Connecting a UUT to the Calibrator

The UUT should be connected to the **voltage** and **current** terminals of the calibrator to allow power to be simulated. The example configuration below shows a *power clamp meter* with the calibrator's current terminals connected to the optional Transmille clamp coil adapter and the calibrator's voltage terminals connected to the power clamp meter voltage input terminals :

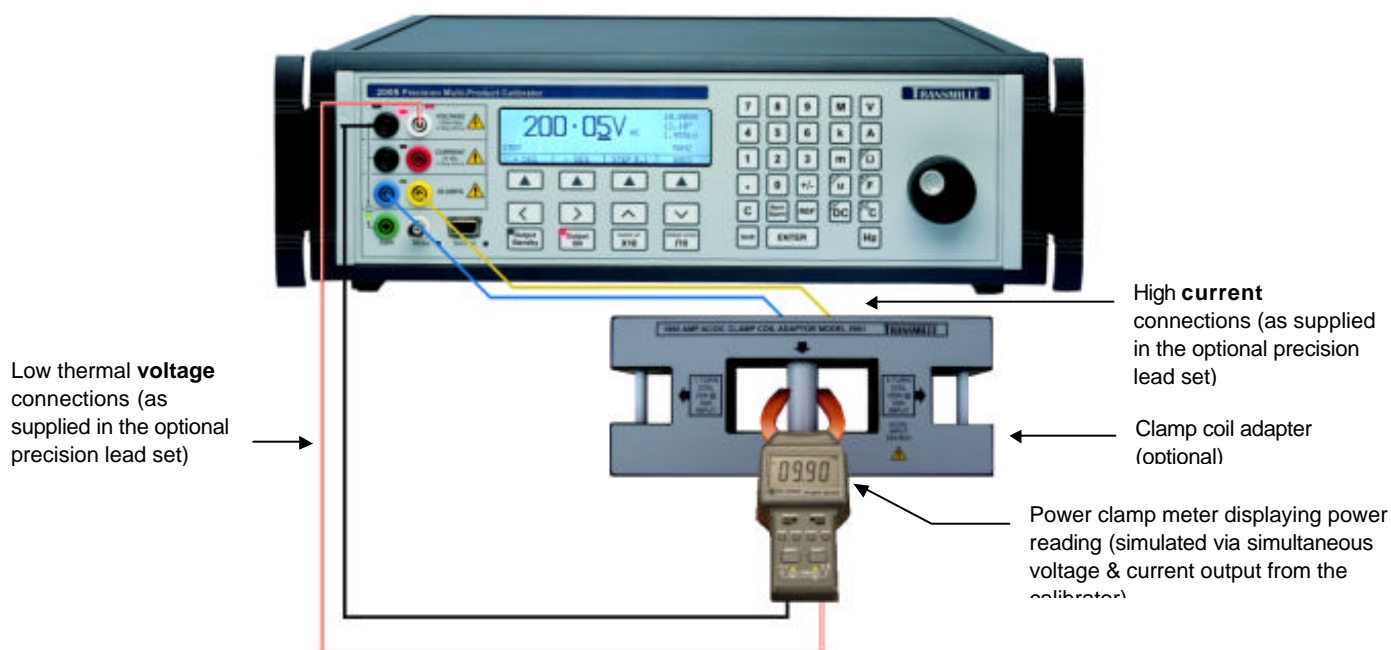

### Starting the Power Calibration Option

To start the power calibration option, press the softkey below the **POWER** menu item



This **NEXT** menu item will change to **BACK** when power mode is selected - this will allow the user to return back to normal **DC** mode.

Power mode softkey

## Power Calibration

The 2000 series calibrator can produce power output by simultaneously outputting an voltage at the **VOLTAGE** terminals and an current at the **HIGH CURRENT** terminals with a fully adjustable phase relationship.

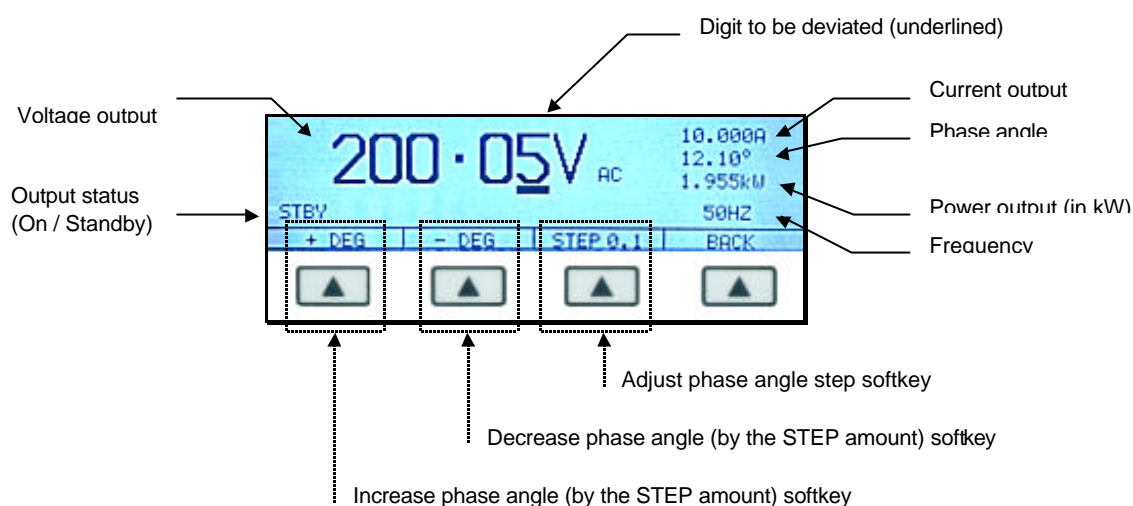

1. Connect the UUT to the calibrator's voltage and high current terminals either directly or through the optional 1 / 5 / 50 clamp coil adapter.
2. Using the keypad enter the voltage, for example 200V :

2 0 0 V ENTER

3. Using the key pad, enter the required current, for example 2A :

2 A

① Note : After entering the current it is **NOT** necessary to press the ENTER key.

Ensure the calibrator output is turned ON by pressing the key.

**Note** : The LED in the top left hand corner of the Output ON key will illuminate and the display will indicate ON in the left hand corner.

① To select DC power, simply press the button while the calibrator is in power mode.

4. Change the phase angle by using the menu items  and  softkeys below the menu items shown.

The phase angle step size can be changed by stepping through the step size menu using the softkey below the menu item

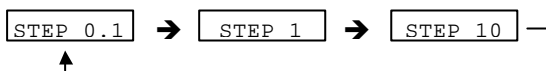

ⓘ Note : Available step sizes are 0.1, 1 & 10

**TIP** The value in kW is calculated and displayed on the right hand side of the display

5. To deviate the power output from the nominal value, use the deviation function to alter the voltage output which will allow the total power output simulated to be altered.

This is controlled by using the left and right arrow keys to select the digit to be increased or decreased

To increase or decrease the digit, simply use the up down keys on the calibrator's keyboard or use the digital potentiometer

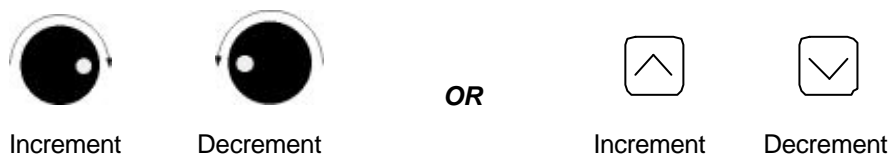

**Note** : The voltage, current and phase settings can be changed at any time by re-entering the value required

Power calibration times can be significantly reduced by using the ProCal calibration software available from Transmille which allows a pre-defined sequence of tests (known as a procedure) to be set up. This allows the computer to automatically step through these tests, control the calibrator, set the correct outputs and record the amount of deviation in relation to the power instrument's specifications.

# 2006A DC Power Option Specifications

General Specifications	
Voltage Range	0 to 1000V DC
Current Range	300mA to 20A
Output Terminals	Voltage output from top (Black & White) terminals 300mA to 2A current output from middle 2A (Black & Red) terminals 2.01A to 20A current output from bottom 20A (Blue & Yellow) terminals Note : Indicator LEDs for both sets of terminals will illuminate to indicate Power mode

## 90 Day Accuracy Relative to Calibration standards (% Watts)

Current Range	Resolution	Voltage Range
		20mV to 1000V
300mA to 2A	200uA	0.04% +/- 0.35mW/Volt
2.01A to 20A	2mA	0.04% +/- 3.5mW/Volt

## 1 Year Accuracy Relative to Calibration standards (% Watts)

Current Range	Resolution	Voltage Range
		20mV to 1000V
300mA to 2A	200uA	0.05% +/- 0.35mW/Volt
2.01A to 20A	2mA	0.05% +/- 3.5mW/Volt

### High Voltage Safety

High voltage output is ramped to allow instruments to auto range  
Standby is automatically activated when setting voltages greater than 20V or 200V from a lower voltage  
Standby is automatically selected for high voltage (>20V) after 20 minutes on the same setting  
High voltage (> 20V) output is indicated to user through an audible warning beep  
An external high voltage output/standby control switch is available as an option

20A available as standard - external amplifier **not** required

Specifications apply between 17°C and 27°C.

Outside this range an allowance of 0.18 x 1 Year Spec. per °C should be added.

Due to continuous development specifications may be subject to change.

# 2006A AC Power Option Specifications

## General Specifications

Voltage Range	1V to 1000V AC
Current Range	300mA to 20A AC
Frequency Range	40 to 400Hz
Output Terminals	Voltage output from top (Black & White) terminals 300mA to 2A current output from middle 2A (Black & Red) terminals 2.01A to 20A current output from bottom 20A (Blue & Yellow) terminals Note : Indicator LEDs for both sets of terminals will illuminate to indicate AC Power mode

## 90 Day Accuracy Relative to Calibration standards (% Watts)

Current Range	Resolution	Voltage Range
		1V to 1kV
300mA to 2A	200uA	0.11% +/- 0.35mW/Volt
2.01A to 20A	2mA	0.09% +/- 3.5mW/Volt

## 1 Year Accuracy Relative to Calibration standards (% Watts)

Current Range	Resolution	Voltage Range
		1V to 1kV
300mA to 2A	200uA	0.13% +/- 0.35mW/Volt
2.01A to 20A	2mA	0.11% +/- 3.5mW/Volt

Frequency range 40Hz to 400Hz

Power Factor = 1

## Phase Specifications

Phase Angle	Resolution / Accuracy
0° to 359.9°	0.1° / 0.8°

2000 Series calibrators **automatically correct for any errors in the phase** caused by inductive loading, for example when using the clamp coil adaptor.

## High Voltage Safety

High voltage output is ramped to allow instruments to auto range  
Standby is automatically activated when setting voltages greater than 20V or 200V from a lower voltage  
Standby is automatically selected for high voltage (>20V) after 20 minutes on the same setting  
High voltage (> 20V) output is indicated to user through an audible warning beep  
An external high voltage output/standby control switch is available as an option

20A available as standard - external amplifier **not** required

Specifications apply between 17°C and 27°C.

Outside this range an allowance of 0.18 x 1 Year Spec. per °C should be added.

Due to continuous development specifications may be subject to change.

# 2041A DC Power Option Specifications

## General Specifications

Voltage Range	0 to 1000V DC
Current Range	300mA to 20A
Output Terminals	Voltage output from top (Black & White) terminals 300mA to 2A current output from middle 2A (Black & Red) terminals 2.01A to 20A current output from bottom 20A (Blue & Yellow) terminals Note : Indicator LEDs for both sets of terminals will illuminate to indicate Power mode

## 90 Day Accuracy Relative to Calibration standards (% Watts)

Current Range	Resolution	Voltage Range
		20mV to 1000V
300mA to 2A	200uA	0.06% +/- 0.35mW/Volt
2.01A to 20A	2mA	0.06% +/- 3.5mW/Volt

## 1 Year Accuracy Relative to Calibration standards (% Watts)

Current Range	Resolution	Voltage Range
		20mV to 1000V
300mA to 2A	200uA	0.07% +/- 0.35mW/Volt
2.01A to 20A	2mA	0.07% +/- 3.5mW/Volt

## High Voltage Safety

High voltage output is ramped to allow instruments to auto range

Standby is automatically activated when setting voltages greater than 20V or 200V from a lower voltage

Standby is automatically selected for high voltage (>20V) after 20 minutes on the same setting

High voltage (> 20V) output is indicated to user through an audible warning beep

An external high voltage output/standby control switch is available as an option

20A available as standard - external amplifier **not** required

Specifications apply between 17°C and 27°C.

Outside this range an allowance of 0.18 x 1 Year Spec. per °C should be added.

Due to continuous development specifications may be subject to change.

# 2041A AC Power Option Specifications

## General Specifications

Voltage Range	1V to 1000V AC
Current Range	300mA to 20A AC
Frequency Range	40 to 400Hz
Output Terminals	Voltage output from top (Black & White) terminals 300mA to 2A current output from middle 2A (Black & Red) terminals 2.01A to 20A current output from bottom 20A (Blue & Yellow) terminals Note : Indicator LEDs for both sets of terminals will illuminate to indicate AC Power mode

## 90 Day Accuracy Relative to Calibration standards (% Watts)

Current Range	Resolution	Voltage Range
		1V to 1kV
300mA to 2A	200uA	0.14% +/- 0.35mW/Volt
2.01A to 20A	2mA	0.12% +/- 3.5mW/Volt

## 1 Year Accuracy Relative to Calibration standards (% Watts)

Current Range	Resolution	Voltage Range
		1V to 1kV
300mA to 2A	200uA	0.16% +/- 0.35mW/Volt
2.01A to 20A	2mA	0.14% +/- 3.5mW/Volt

Frequency range 40Hz to 400Hz

Power Factor = 1

## Phase Specifications

Phase Angle	Resolution / Accuracy
0° to 359.9°	0.1° / 0.8°

2000 Series calibrators **automatically correct for any errors in the phase** caused by inductive loading, for example when using the clamp coil adaptor.

## High Voltage Safety

High voltage output is ramped to allow instruments to auto range  
Standby is automatically activated when setting voltages greater than 20V or 200V from a lower voltage  
Standby is automatically selected for high voltage (>20V) after 20 minutes on the same setting  
High voltage (> 20V) output is indicated to user through an audible warning beep  
An external high voltage output/standby control switch is available as an option

20A available as standard - external amplifier **not** required

Specifications apply between 17°C and 27°C.

Outside this range an allowance of 0.18 x 1 Year Spec. per °C should be added.

Due to continuous development specifications may be subject to change.